

4,724" x 4,724" x 1,496"

120 x 120 x 38 mm

125XR5

**ETRI**

AC Axial Fans

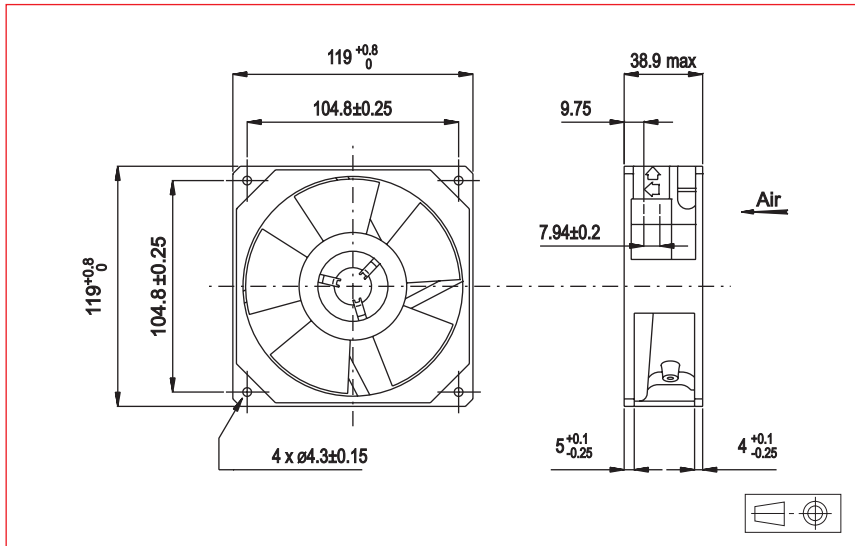

Approvals



Life expectancy

L-10 LIFE AT 40°C:  
80 000 hours

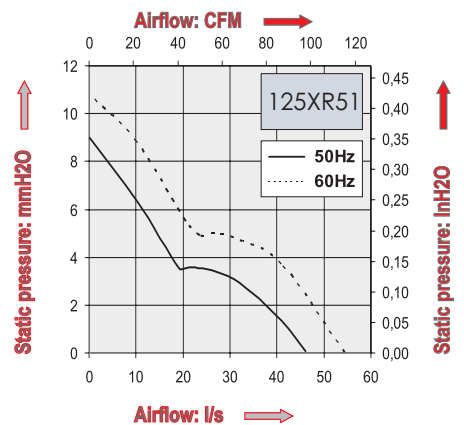

**AC Motor**  
 Electrical protection: impedance protected  
 Housing material: aluminium  
 Impeller material: plastic UL 94 V0  
 Maximum weight: 560 g  
 Bearing system: ball bearings  
 Connection: terminals

Single phase  
 IP 20

**Available with:**  
 - Flying leads - IP 54  
 - Speed sensor

Part Number	Nominal voltage	Airflow	Noise level	Nominal speed	Frequency	Input Power	Nominal current	Starting current	Operating temperature	
	V	l/s	dB(A)	RPM	Hz	W	mA	mA	Min.°C	Max.°C
125XR5182002	115	44	43	2800	50	16	200	310	-54	100
		53	48	3200	60	15	180	260	-54	100
125XR5181002	208-240	44	43	2800	50	18	125	170	-54	100
		53	48	3200	60	15	105	150	-54	100

**Additional versions:**  
 Dual voltage 115V - 230V - other voltages  
 Shock and vibration protected - salt spray protected - marine specifications